

**A**  
SIZE

THIRD ANGLE

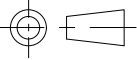

PROJECTION

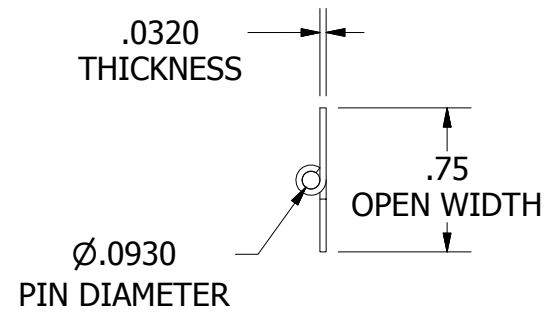
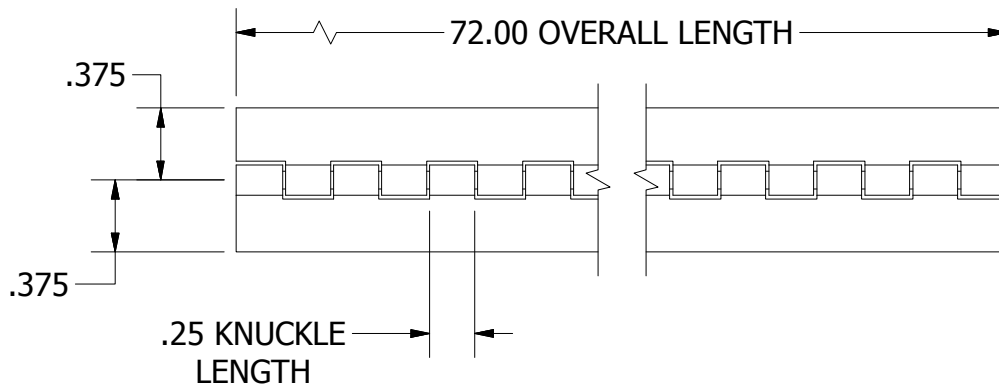

**NOTES:**

- 1.) HINGE DRAWN KNUCKLE UP.
- 2.) ALL HINGES ARE COMMERCIAL DIE CUT QUALITY.
- 3.) RANGE OF MOTION IS APPROXIMATELY 270°.
- 4.) DIMENSIONS AND TOLERANCES APPLY TO PART PRIOR TO ANY FINISH APPLICATION.

|   |                 |                  |  |
|---|-----------------|------------------|--|
| PART NUMBER:  |                 | SCALE:           |  |
| <b>A03201272</b>  |                 | <b>1:1</b>       |  |
| LEAF MATERIAL:  | PIN MATERIAL:   | FINISH:          |  |
| <b>ALUMINUM</b>   | <b>ALUMINUM</b> | <b>MILL</b>      |  |
| MARLBORO STANDARD TOLERANCES<br>UNLESS OTHERWISE SPECIFIED<br>(ALL TOLERANCES ARE NON-CUMULATIVE) |                 |                  |  |
| .X ± .060   | .XXX ± .015     | FRACTIONAL: 1/16 |  |
| .XX ± .030  | .XXXX ± .005    | ANGULAR: 1°      |  |



11750 Marlboro Avenue, NE  
Alliance, Ohio 44601  
www.marlbороhinge.com  
sales@marlbороhinge.com  
Phone 330-935-2445  
Fax 330-935-2748