

A
SIZE

THIRD ANGLE

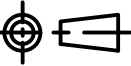

PROJECTION

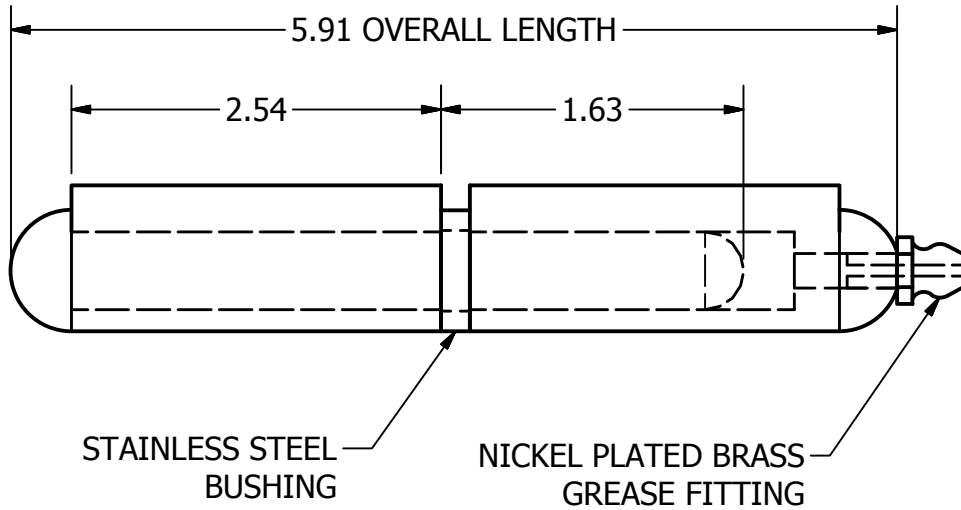
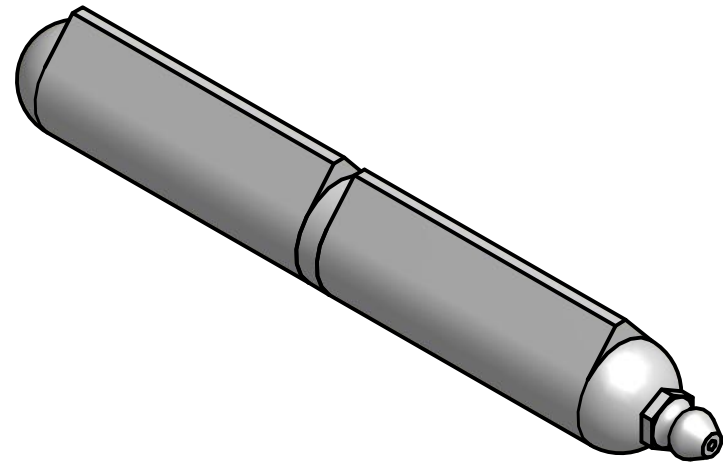

Ø.500 PIN DIAMETER

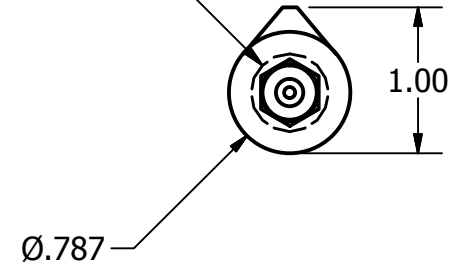

PART NUMBER: AFSSP-150BRG/F		SCALE: NTS
LEAF MATERIAL: ALUMINUM	PIN MATERIAL: TYPE 302/304 STAINLESS STEEL	FINISH: MILL
MARBORO STANDARD TOLERANCES UNLESS OTHERWISE SPECIFIED (ALL TOLERANCES ARE NON-CUMULATIVE)		
.X ± .060	.XXX ± .015	FRACTIONAL: 1/16
.XX ± .030	.XXXX ± .005	ANGULAR: 1°

Marlboro
MANUFACTURING INC.

11750 Marlboro Avenue, NE
Alliance, Ohio 44601
www.marlbороhinge.com
sales@marlbороhinge.com
Phone 330-935-2445
Fax 330-935-2748