

A
SIZE

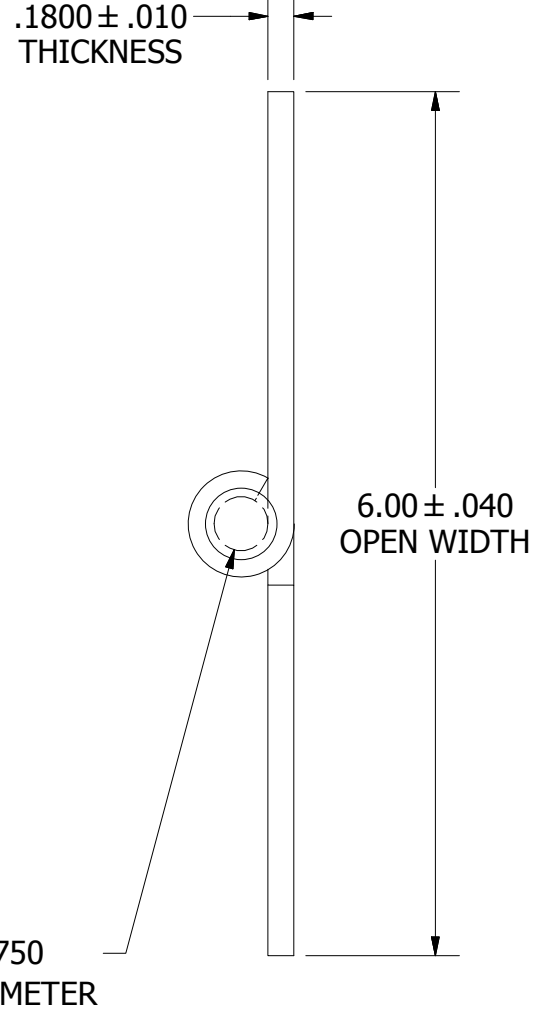
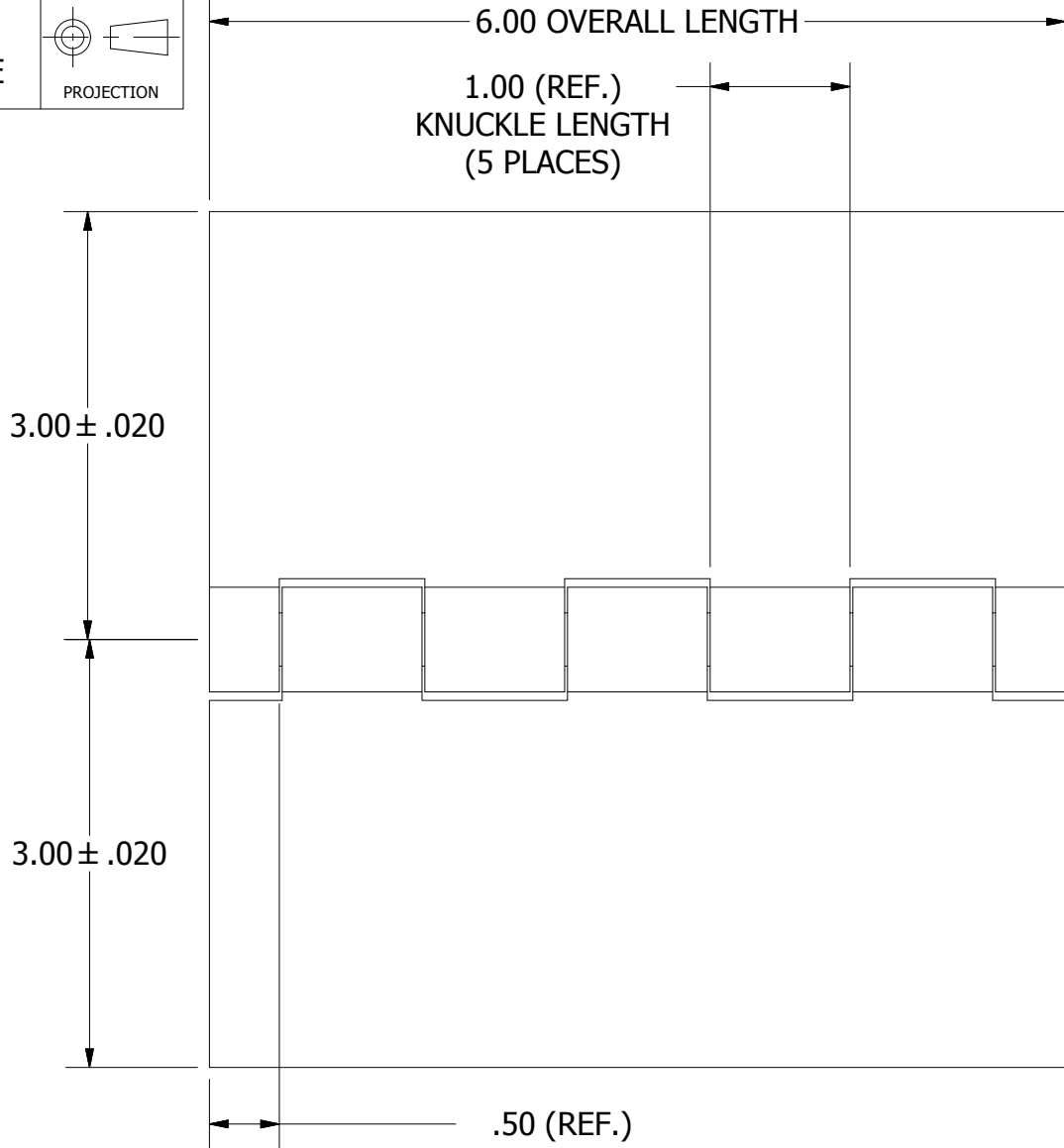
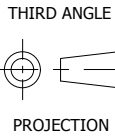

- NOTES:**
- 1.) HINGE DRAWN KNUCKLE UP.
 - 2.) ALL HINGES ARE COMMERCIAL DIE CUT QUALITY.
 - 3.) RANGE OF MOTION IS APPROXIMATELY 270°.
 - 4.) DIMENSIONS AND TOLERANCES APPLY TO PART PRIOR TO ANY FINISH APPLICATION.
 - 5.) HINGE PIN SPUN ONE END (REMOVABLE)

.50 (REF.)
END KNUCKLE
(BOTH ENDS)

PART NUMBER: BTS18606037R		SCALE: 3:4
LEAF MATERIAL: STEEL	PIN MATERIAL: STEEL	FINISH: MILL
MARLBORO STANDARD TOLERANCES UNLESS OTHERWISE SPECIFIED (ALL TOLERANCES ARE NON-CUMULATIVE)		
.X ± .060	.XXX ± .015	FRACTIONAL: 1/16
.XX ± .030	.XXXX ± .005	ANGULAR: 1°



11750 Marlboro Avenue, NE
Alliance, Ohio 44601
www.marlborohinge.com
sales@marlborohinge.com
Phone 330-935-2445
Fax 330-935-2748