

**A**  
SIZE

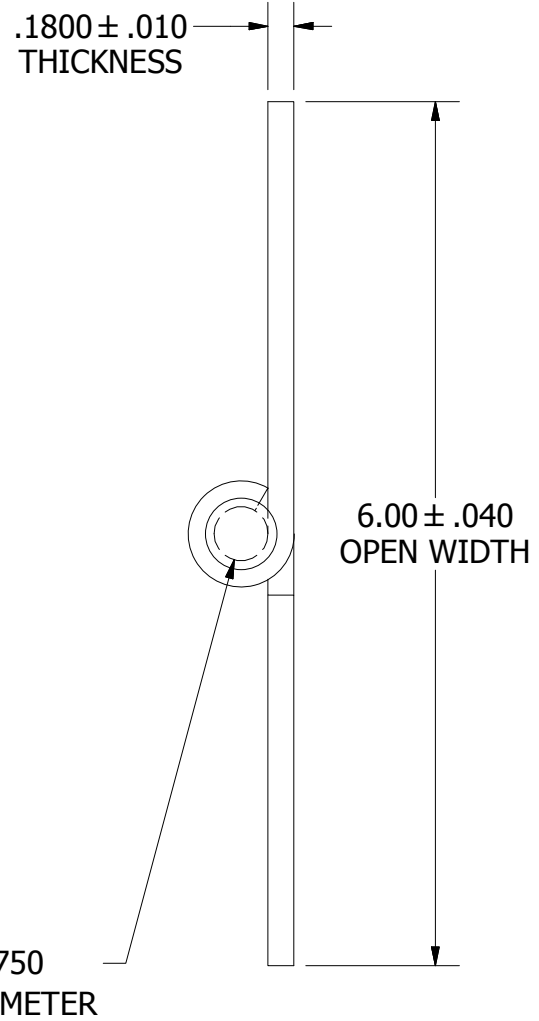

- NOTES:**
- 1.) HINGE DRAWN KNUCKLE UP.
  - 2.) ALL HINGES ARE COMMERCIAL DIE CUT QUALITY.
  - 3.) RANGE OF MOTION IS APPROXIMATELY 270°.
  - 4.) DIMENSIONS AND TOLERANCES APPLY TO PART PRIOR TO ANY FINISH APPLICATION.
  - 5.) HINGE PIN SPUN BOTH ENDS.

PART NUMBER: <b>BTSS18606037</b>		SCALE: <b>1:1</b>
LEAF MATERIAL: TYPE 304 STAINLESS STEEL	PIN MATERIAL: TYPE 304 STAINLESS STEEL	FINISH: <b>2B</b>
MARLBORO STANDARD TOLERANCES UNLESS OTHERWISE SPECIFIED (ALL TOLERANCES ARE NON-CUMULATIVE)		
.X ± .060	.XXX ± .015	FRACTIONAL: 1/16
.XX ± .030	.XXXX ± .005	ANGULAR: 1°

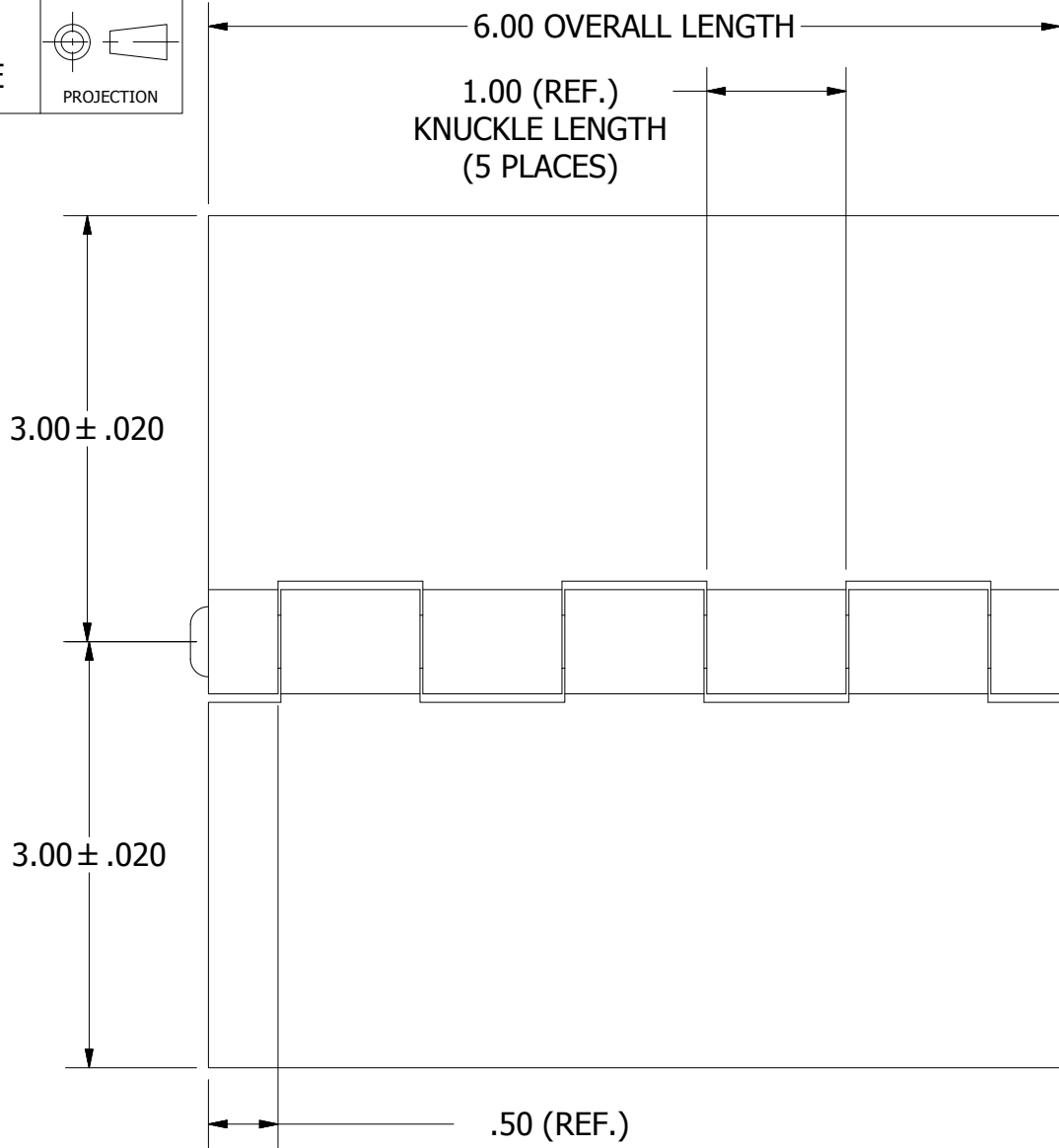
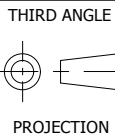

11750 Marlboro Avenue, NE  
Alliance, Ohio 44601  
www.marlborohinge.com  
sales@marlborohinge.com  
Phone 330-935-2445  
Fax 330-935-2748