

A
SIZE

THIRD ANGLE

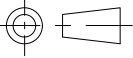

PROJECTION

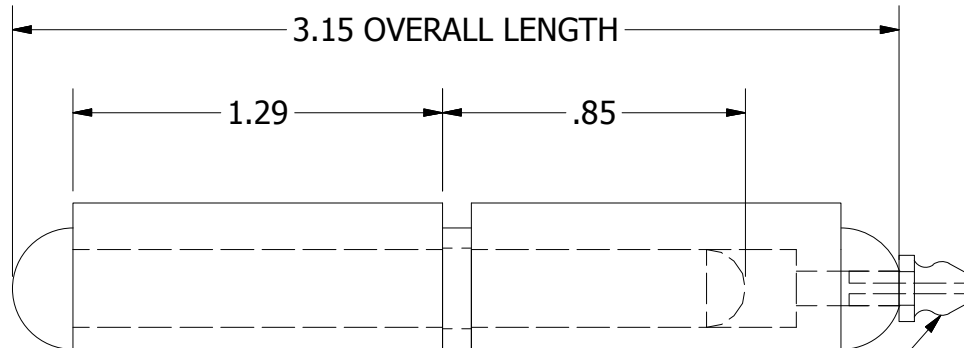
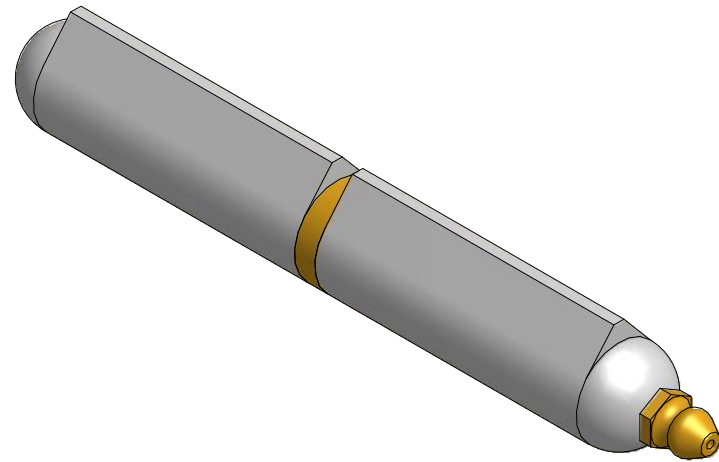

BRASS BUSHING

BRASS GREASE FITTING

Ø.315 PIN DIAMETER

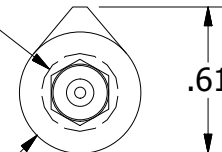

Ø.510

PART NUMBER:		SCALE:	
FBP-080G/F		NTS	
LEAF MATERIAL:	PIN MATERIAL:	FINISH:	
STEEL	BRASS	MILL	
MARLBORO STANDARD TOLERANCES UNLESS OTHERWISE SPECIFIED (ALL TOLERANCES ARE NON-CUMULATIVE)			
.X ± .060	.XXX ± .015	FRACTIONAL: 1/16	
.XX ± .030	.XXXX ± .005	ANGULAR: 1°	



11750 Marlboro Avenue, NE
Alliance, Ohio 44601
www.marlbороhinge.com
sales@marlbороhinge.com
Phone 330-935-2445
Fax 330-935-2748