

**A**  
SIZE

THIRD ANGLE

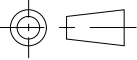

PROJECTION

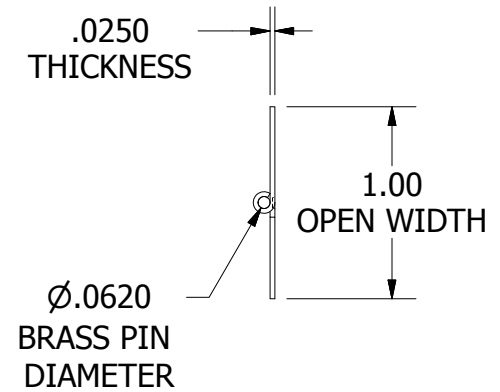
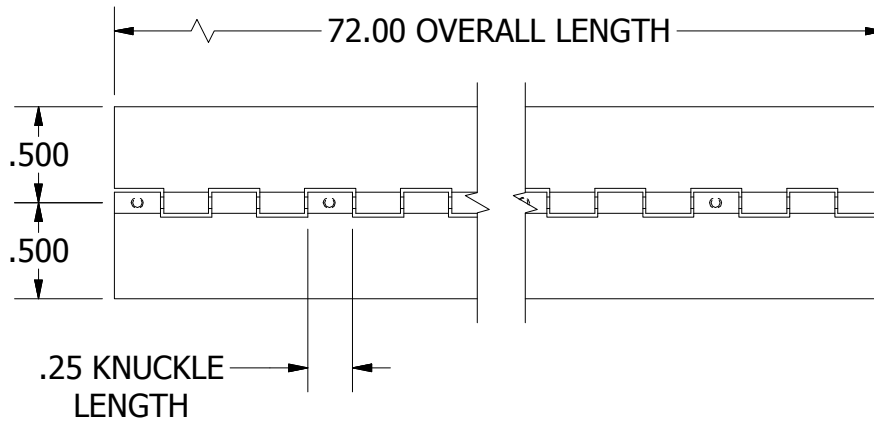

**NOTES:**

- 1.) HINGE DRAWN KNUCKLE UP.
- 2.) HINGE STAKED EVERY 1" (BACKSIDE) TO RETAIN PIN.
- 3.) ALL HINGES ARE COMMERCIAL DIE CUT QUALITY.
- 4.) RANGE OF MOTION IS APPROXIMATELY 270°.
- 5.) DIMENSIONS AND TOLERANCES APPLY TO PART PRIOR TO ANY FINISH APPLICATION.

PART NUMBER:		SCALE:	
<b>S02501672B</b>		<b>1:1</b>	
LEAF MATERIAL:	PIN MATERIAL:	FINISH:	
<b>STEEL</b>	<b>BRASS</b>	<b>MILL</b>	
MARLBORO STANDARD TOLERANCES UNLESS OTHERWISE SPECIFIED (ALL TOLERANCES ARE NON-CUMULATIVE)			
.X ± .060	.XXX ± .015	FRACTIONAL: 1/16	
.XX ± .030	.XXXX ± .005	ANGULAR: 1°	

**Marlboro**  
MANUFACTURING INC.

11750 Marlboro Avenue, NE  
Alliance, Ohio 44601  
www.marlborohinge.com  
sales@marlborohinge.com  
Phone 330-935-2445  
Fax 330-935-2748