

A
SIZE

THIRD ANGLE

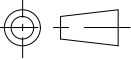

PROJECTION

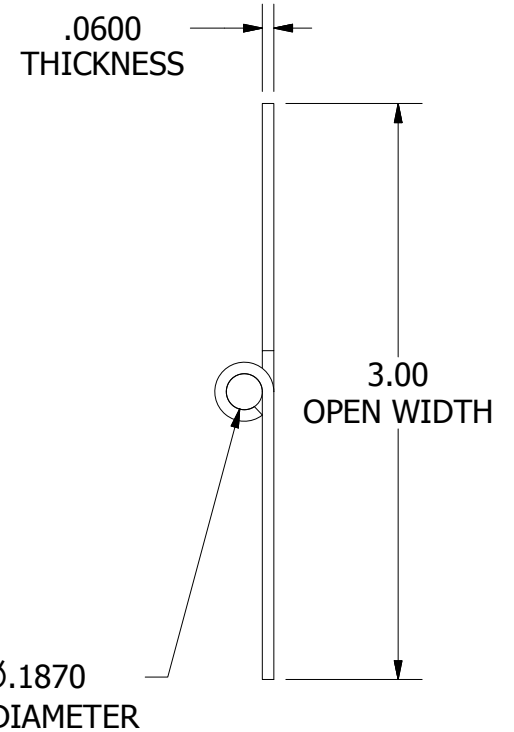
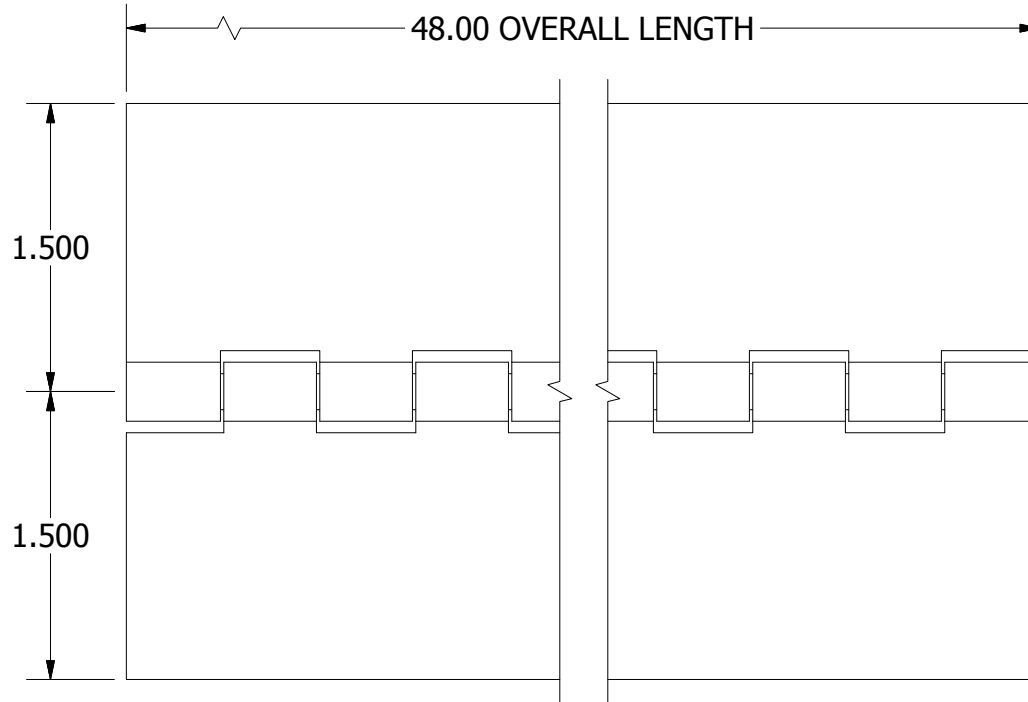

NOTES:

- 1.) HINGE DRAWN KNUCKLE UP.
- 2.) ALL HINGES ARE COMMERCIAL DIE CUT QUALITY.
- 3.) RANGE OF MOTION IS APPROXIMATELY 270°.
- 4.) DIMENSIONS AND TOLERANCES APPLY TO PART PRIOR TO ANY FINISH APPLICATION.

| | | |
|---|---------------|------------------|
| PART NUMBER: | | SCALE: |
| S06504848 | | 1:1 |
| LEAF MATERIAL: | PIN MATERIAL: | FINISH: |
| STEEL | STEEL | MILL |
| MARLBORO STANDARD TOLERANCES UNLESS OTHERWISE SPECIFIED (ALL TOLERANCES ARE NON-CUMULATIVE) | | |
| .X ± .060 | .XXX ± .015 | FRACTIONAL: 1/16 |
| .XX ± .030 | .XXXX ± .005 | ANGULAR: 1° |



11750 Marlboro Avenue, NE
Alliance, Ohio 44601
www.marlbороhinge.com
sales@marlbороhinge.com
Phone 330-935-2445
Fax 330-935-2748